

new

CCM52



TAGLIAFORMAGGIO

- Macchina per il taglio di formaggio a fette
- Adatta al taglio di formaggi di differenti consistenze
- Massima sicurezza:
 - Comando bimanuale che permette all'operatore di lavorare in estrema sicurezza
 - Protezioni laterali
- Lama teflonata
- Piano di lavoro estraibile e lavabile in lavastoviglie
- Taglio estremamente pulito e preciso.

CHEESE SLICER

- Slice Cutting Machine for cheese.
- Designed for slicing cheese with different consistencies
- Maximum security:
 - Two hand safety control for optimum operator safety
 - Side Protections
- Teflon Blade
- Removable and dishwasher safe worktop.
- Extremely clean, precise cutting.

TRANCHEUR A' FROMAGE

- Machine pour couper moules de fromage
- Adaptée pour la découpe de fromages de différentes consistances
- Sécurité Maximale:
 - Dispositif de commande bimanuelle qui permet à l'opérateur de travailler en toute sécurité
 - Protections latéraux
- Lame au Teflon
- Plan de travail démontable et lavable en lave-vaisselle
- Découpe extrêmement nette et précise.

KÄSESCHNEIDER

- Maschine zum Schneiden von Käse in Scheiben
- Geeignet zum Schneiden von Käse verschiedener Konsistenzen
- Maximale Sicherheit:
 - Bimanuelle Steuerung, die dem Bediener ein extrem sicheres Arbeiten ermöglicht
 - Seitliche Schutzvorrichtungen
- Teflonbeschichtete Klinge
- Abnehmbare und spülmaschinenfeste Arbeitsfläche
- Äußerst sauberer und präziser Schnitt.

CORTADORA DE QUESO

- Máquina para cortar queso en trozos
- Adecuado para cortar queso de diferentes consistencias
- Máxima seguridad:
 - Control manual doble que permite al operador trabajar con extrema seguridad
 - Protecciones laterales
- Cuchilla recubierta de teflón
- Superficie de trabajo extraíble (y apta para el lavavajillas)
- Corte extremadamente limpio y preciso.



CARATTERISTICHE TECNICHE - TECHNICAL SPECIFICATIONS - TECHNISCHE DATEN - CARACTÉRISTIQUES - ESPECIFICACIONES

		CCM52
Alimentazione - Power supply - Alimentation - Versorgung - Alimentación	V./Hz	230/1/Hz
Potenza assorbita - Power input - Puissance absorbée - Aufgenommene Leistung - Potencia absorbida	kW (HP)	0,55 (0,70)
Lunghezza lama - Blade length - Longueur de la lame - Messerlänge - Longitud cuchilla	mm	285
Altezza di taglio - Cut height - Hauteur de coupe - Schnitthöhe - Altura de corte	mm	290
Diametro massimo prodotto lavorabile - Workable product maximum diameter - Max diamètre du product travaillable - Maximaler Durchmesser des bearbeitbaren Produkts - Diametro Maximo del producto trabajable	Ø mm	520
Peso netto - Net weight - Poids net - Nettogewicht - Peso neto	kg	60

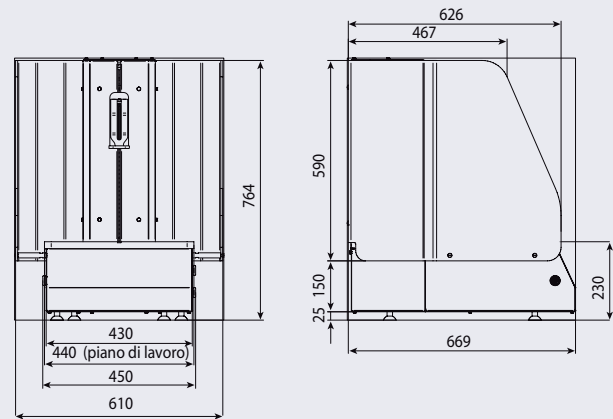

Macchina conforme alle norme CE in materia di igiene e di sicurezza.

The machine complies with CE standards in terms of hygiene and safety.

